



**Instruction manual for the  
digital gear indicator and shift light unit**

***SureShift starting from serial no. 001711***

**Suchen Sie die deutsche Bedienungsanleitung?**

Besuchen Sie „support“ auf [www.motogadget.de](http://www.motogadget.de).



Thank you very much for purchasing a high quality product by *motogadget*.

Please read the following information and recommendations thoroughly and follow these instructions during installation and use of the instrument. No liability is assumed by *motogadget* for damage or defects resulting from negligence or failure to follow the operating and installation guide.

### **Important!**

**In delivery status the device is in a testing mode to support installation and easy electrical checking. After the first gear teaching the testing mode will be deactivated and can not be activated again.**

**Please follow all instructions step by step. Each installation and setting point must successfully finished before the next step will be started.**

**Configuration and gear teaching have to be done before using the SureShift. Nothing will be displayed without configuration and gear teaching.**

**Not every vehicles speedometer sensor und ignition system is compatible with the SureShift. Please read chapter 8.2.**

### **CAUTION FOR ALL U.S. CUSTOMERS**

**THIS PRODUCT IS NOT D.O.T. APPROVED AND INTENDED FOR SHOW USE ONLY!**

**CAUTION: IF YOU ARE NOT A CERTIFIED MOTORCYCLE TECHNICIAN PLEASE STOP HERE AND ASK YOUR LOCAL MOTORCYCLE SHOP FOR PROFESSIONAL INSTALLATION!**

**Find product outside dimensions, 2D or 3D drawings at [www.motogadget.com](http://www.motogadget.com)**

*Contact:*

motogadget GmbH  
Köpenicker Str. 145  
D-10997 Berlin  
Germany  
fon +49-30-27 59 19 20  
fax +49-30-27 59 19 22  
[www.motogadget.com](http://www.motogadget.com)  
[info@motogadget.de](mailto:info@motogadget.de)

## 1 Review of delivery

All products from *motogadget* are thoroughly checked to ensure they are completely fault free when dispatched. Please check the received goods immediately for possible transport damage. If you find any damage or other deficiencies, please contact us immediately.

In this regard we refer to our general terms of business and delivery, which are published under [www.motogadget.com](http://www.motogadget.com). Should a return of the received delivery be agreed, please note that we only take back goods in their original packaging. The instrument and its accessories must be returned within the legal period of time and without any traces of use. We do not assume any liability for returns which are insufficiently insured or packed.

## 2 Exclusion of liability

**VERIFY IN ANY CASE THE ADJUSTED THRESHOLDS WILL RELEASE AT THE CORRECT ENGINE SPEED. INACCURATE SETTINGS IN SETUP AT ENGINE SPEED FILTER OR IGNITION IMPULSE MAY LEAD TO WRONG DISPLAY.**

**MOTOGADGET ACCEPTS NO LIABILITY FOR DIRECT OR INDIRECT DAMAGE OR SUBSEQUENT DAMAGE OF ANY KIND RESULTING FROM THE USE, INSTALLATION OR CONNECTION OF THE INSTRUMENT, THE SENSORS OR OTHER DELIVERED EQUIPMENT. THIS EXCLUSION OF LIABILITY PARTICULARLY INCLUDES DAMAGE TO PERSONS, MATERIAL LOSSES AND FINANCIAL DAMAGES. THE USE OF THE SURESHIFT AND ALL OF ITS ACCESSORY PARTS IN AREAS OF PUBLIC TRAFFIC IS UNDERTAKEN AT THE USER'S OWN RISK.**

**INSTRUMENT HOUSINGS AND ALL OTHER DELIVERED PARTS MUST NOT BE OPENED OR DISMANTLED. IN CASE OF NON-COMPLIANCE ALL GUARANTEE CLAIMS BECOME INVALID. THE USE OF THE DELIVERED INSTRUMENTS, SENSORS AND ACCESSORY PARTS FOR RACING OR OTHER COMPETITIONS, AS WELL AS ALL USES THAT DO NOT CORRESPOND TO THE RECOMMENDED APPLICATION RENDER ALL GUARANTEE CLAIMS INVALID.**

### 2.1 Duty of registration

The SureShift does not have to be registered.

## 3 Technical data

Diameter and height	33 mm / 14,4 mm
Weight incl. cable	31 g
Treated fastening bores	2 x M3, 4 mm deep
Current consumption	ca. 200 mA (load dependent)
Operating voltage	7 – 18V (protected against voltage spikes)
Operating temperature	-20°... + 80°C
Display	LED Matrix of 37 super bright LED
Brightness sensor	build in (reduce Display brightness in dark ambience)
Standard display	gear 1-6 + idle gear
Threshold A	adjustable from 0 – 29900 U/min
Threshold B	adjustable from 0 – 29900 U/min

## 4 Features

The display which is made of 35 ultra bright LED guarantees a perfect visibility under all brightness conditions. The integrated brightness sensor reduces the display brightness in dark ambience.

### 4.1 Gear indicator

After teaching all vehicle gears the SureShift will always display the current gear which can be gear number 1 – 6 and idle gear.

The device is calculating the current gear by using the ratio between vehicle speed and engine speed. If the clutch is activated, no gear calculation can be performed because there is no fixed reference between vehicle speed and engine speed. That means: only with released clutch the correct gear will be displayed.

### 4.2 Threshold A

This stage is an advance warning. If this limit is exceeded, the display changes to the inverse mode. In Setup menu this threshold will be adjusted by changing the then thousand, thousand and hundred numeric.

### 4.3 Threshold B

This stage indicates the shift point. If this limit is exceeded, the display will flash with maximum LED brightness and a frequency of 5Hz. In Setup menu this threshold will be adjusted by changing the then thousand, thousand and hundred numeric.

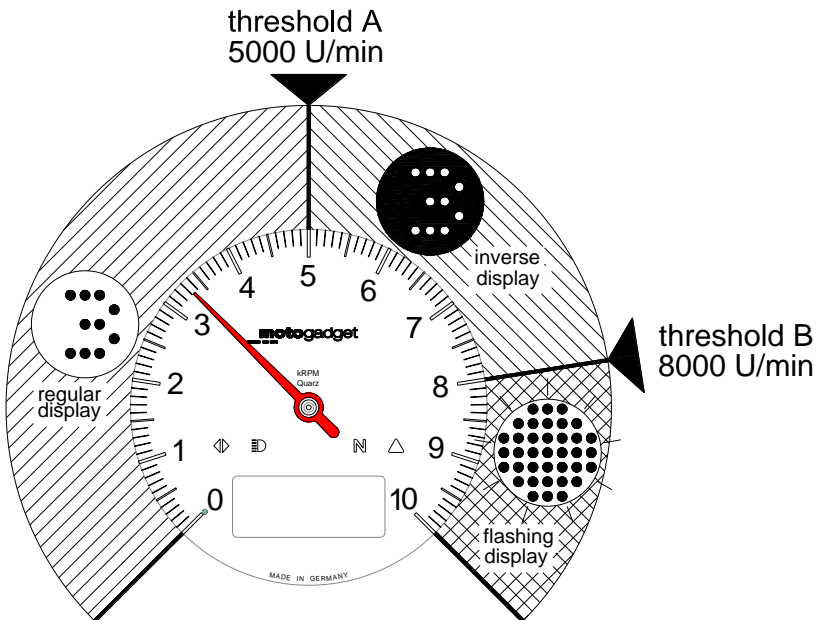

### 4.4 Engine speed ring

The current engine speed is displayed as a ring. The scale end of the ring is the adjusted threshold with the lower RPM. That means the ring shows the distance of the current engine speed to the threshold A, and if it is deactivated to threshold B.

## 5 Required materials for installing and connecting the instrument

Since the SureShift is suitable for a variety of vehicles, **additional materials** might be necessary in order to mount the instrument to an individual vehicle. Such materials can include:

- mounting bracket for the instrument and fitting screws for the bracket
- mounting bracket for the speedometer sensor
- cables or cable extensions for voltage-supply, ignition-signal and idle gear connection
- assembly materials such as cable ties, plug connectors, shrink hose, soldering iron, solder etc.

The use of the original wiring diagram is recommended.

If your vehicle comes with a CDI ignition (**Capacitor Discharge Ignition** - used for Quads, Scooters and trail bikes), you need additionally the motogadget ignition signal pickup (part number 9000001).

## 6 General safety instructions

- For safety reasons the vehicle **battery must be disconnected** prior to the installation.
- Take particular care that all delivered parts are fastened securely to your vehicle. This is important for your own and other peoples' safety.
- Make sure that your vehicle is equipped with **interference suppressing spark plugs and connector cables!**

Use of with non-suppressed ignition systems can lead to damage to the device.

## 7 Installation of the instrument

To ensure correct fastening two metric fastening screws must be used (M3). It is important to select screws appropriate to the thickness of the used mounting bracket. We also recommend the use of additional washers and screw adhesive. Furthermore, the **maximum torque** applied to the M3 fastening screws must not exceed **4 Nm**.

## 8 Connecting of the instrument

### 8.1 Cable routing recommendations

Before routing cables look for suitable cable paths. The cables should be as far away as possible from hot parts of the engine. Make sure you take note of the required lengths of cables before cutting them for best fit. It is important here to consider the full lock of the handlebars as well as the front and rear wheel travel. All cables should be routed free of kinks and should not be subject to any tension. In addition, the cables have to be properly isolated, especially in places where mechanical wear can take place.

### 8.1.1 Cable colours, functions, and connections

<b>SureShift</b>		
<b>Cable colour</b>	<b>Function</b>	<b>Connection</b>
Red	Voltage supply	Plus (+) "switched" and <b>fused</b> voltage of the wiring harness)
Black	Earth connection	vehicle earth
Yellow	Engine speed signal cable  <b>Attention! This cable must not be connected to the high-voltage side of the ignition!</b>	Leads to the negative pole (clamp 1 or -) at one ignition coil.  In case of a CDI-Ignition you must use the motogadget ignition signal pickup.
White	Connection to the speed sensor	Leads to the signal cable of the OEM speed sensor, or delivered sensor that is connected to earth
Green	Idle gear indication	Leads to the idle gear switch that switches to earth
Blue	No function	Not connected

### 8.2 Connecting the SureShift

#### a) red and black cable

These cables are for power supply. The red cable will be connected with switched positive and fused with the delivered 1A cable fuse. The black cable will be connected with earth.

Operating the instrument without a battery in the vehicle's electrical system is not possible. Please ensure that the polarity of the supply voltage is correct.

**The minimal supply cable width is 0,75mm<sup>2</sup>. You must fuse the +12V power supply cable with the delivered cable fuse (1A). Make sure you are capable to connect the instrument properly. If not let a certified motorcycle technician do the job!**

**Test: Switch the ignition on – now the SureShift display must two times flashing and then stay dark.**

#### b) green cable

Connect this cable with the delivered push button. The push button's other end will be connected with vehicle earth. Fix the push button temporarily at the handle bar (use tape or cable ties). After finishing setup and gear teaching the green cable will be connected with vehicle's neutral switch.

**Test: switch ignition on and press the push button after the display has flashing – now the complete display must illuminate during holding the push button.**

#### c) white cable

If the OEM speed sensor of your vehicle is compatible with the SureShift (see compatibility list at support on [www.motogadget.com](http://www.motogadget.com)) connect the white cable with the signal output of the speed sensor.

If your speed sensor is not compatible, connect the white cable with the delivered speed sensor. Connect speed sensor's other end with the SureShift black cable.

For signal triggering **both** delivered magnets must be attached to one wheel with epoxy glue. It doesn't matter where the magnets will be attached (close to the centre or far from the centre). It is important that both magnets are aligned exactly in one line which leads through the wheel centre. The speedometer sensor has to be attached to the vehicle by using a self made holding bracket. The sensor tip has to be fastened parallel to the magnet's surface. The gap between the magnet and the sensor must not exceed 4 mm and the sensor must not touch the magnet or any other rotating parts. The sensor holding bracket has to be made sufficiently stable in order to prevent any distance changes during any driving situations. The maximum mounting torque of the sensor nuts is 2 Nm. For secure mounting we recommend to use screw adhesive (medium strength).

**The magnet will be defective if it is exposed temperatures higher than 100°C or 212°F (i.e. hot brakes).**

**Test: switch ignition on and rotate the wheel which triggeres the speed sensor- now the display must show a horizontal bar (during wheel rotation).**

#### **d) yellow cable**

Connect this cable with ignition coil terminal "1". This terminal is also connected with ignition box or breaker contact.

If your vehicle comes with a CDI ignition system, you have to use the motogadget Ignition signal pickup (Order # 9000001).

If your vehicle is equipped with stick coils (coil and spark plug are one part) which is connected with a 3 wire cable; you can not use the SureShift with your vehicle.

**Test: switch ignition on and start the engine – now the display must show a horizontal bar (during engine is running).**

In case of occurring problems, check your electrical connection; make sure the speed sensor / ignition system is compatible.

**If all tests have been finished successfully**, the device is ready for adjusting and gear teaching. Once the gear teaching is done you can not do this test procedure again. If you like to check the signals please follow chapter 11.1.

## **9 Setup**

**To adjust the instrument and start the gear teach you have to activate the setup menu as follows: After switching power on the display is flashing two times. Press the push button shortly two times during the flashing.**

The setup menu is build serially. That means you can not jump directly into a menu. Every menu has to be opened, starting from menu 1 and ending at menu 5. You can leave the setup at every time by switching the power supply off. All adjusted parameters will be saved.

## 9.1 Menu 1 – Ignition impulse

This menu will adjust the amount of ignition impulses by crank revolution.

A short push button activation changes to the next character.

A long push button activation changes to menu 2.

Following adjustment options are available:

- **A** - means 1 ignition pulse per 4 revolutions
- **B** - means 1 ignition pulse per 2 revolutions - 1 cylinder, 4 stroke
- **C** - means 1 ignition pulse per 1,5 revolutions
- **D** - means 1 ignition pulse per 0,75 revolutions
- **1** - means 1 ignition pulse per 1 revolutions - 4 cylinder 4 stroke with 2 coils
- **2** - means 1 ignition pulse per 0,5 revolutions
- **3** - means 1 ignition pulse per 0,33 revolutions
- **4** - means 1 ignition pulse per 0,25 revolutions
- **5** - means 1 ignition pulse per 0,2 revolutions
- **6** - means 1 ignition pulse per 0,16 revolutions - V6 or 6 cylinder engines
- **7** - means 1 ignition pulse per 0,14 revolutions
- **8** - means 1 ignition pulse per 0,125 revolutions - V8 engines
- **9** - means 1 ignition pulse per 0,11 revolutions

### Examples:

1 cylinder, 4 stroke, 1 ignition coil	= option B	(SR 500, XT 500)
4 cylinder, 4 stroke, 4 ignition coils	= option B	
4 cylinder, 4 stroke, 2 ignition coils	= option 1	(GSXR 1000)
2 cylinder, 4 stroke, 1 ignition coil	= option 1	(Harley Davidson, dual fire)
2 cylinder, 4 stroke, 2 ignition coils	= option B	(Harley Davidson, single fire)

### How do I know my adjusting option?

99% of all motorcycles have option B or 1.

Chose option 1. Now go to menu 4 and adjust threshold B to 2000 rev/min.

Switch ignition off and on to save all adjustments and leaving the setup.

Start the engine. At 2000 rev/min the display must flash. Is the display flashing already at 1000 rev/min, you have to adjust option B.

## 9.2 Menu 2 – Threshold A

This menu allows you to adjust the threshold A. The upper 3 LED indicate which character is currently adjusted. If the left LED is blinking, the ten thousand character will be adjusted, the middle LED indicate the thousand and the right LED the hundred character.

The setting process starts with the ten thousand character. A short push button operation changes the character value (0-2). A long push button activation switches to the thousand character.

A short push button operation changes the character value (0-9). A long push button activation switches to the hundred character. A short push button operation changes the character value (0-9). A long push button operation switches to the next menu.

## 9.3 Menu 3 – Engine speed filter

In some cases it is necessary to adjust the filtering of the ignition pulses. **The factory setting is filter B. This setting will work with 99% of all ignition systems.** If the gear indication is not working reliable and the thresholds does not indicate at the correct engine speed, a different value has to be adjusted. This value has to be finding out by trying. Therefore set the Threshold A to 5000 rpm and activate the engine speed ring. Now change the Engine speed filter value leave the setup and observe the ring. If the ring is stable and not jumping you have chosen the right value. Change the filter value with a short push button operation. Switch to the next menu with a long push button operation.



## **9.4 Menu 4 – Threshold B**

This menu allows you to adjust the threshold B. The lower 3 LED indicate which character is currently adjusted. If the left LED is blinking, the ten thousand character will be adjusted, the middle LED indicate the thousand and the right LED the hundred character.

The setting process starts with the ten thousand character. A short push button operation changes the character value (0-2). A long push button activation switches to the thousand character.

A short push button operation changes the character value (0-9). A long push button activation switches to the hundred character. A short push button operation changes the character value (0-9). A long push button operation switches to the next menu.

## **9.5 Menu 5 – Engine speed ring and start gear teach**

Switch the engine speed ring feature on / off or start gear teach process in this menu.

A short push button operation change between ring on (D), ring off (A) and start gear teach (R).

A long push button operation activates the chosen option and finishes the setup. All settings will be saved.

### **9.5.1 Gear teach**

Please start the gear teaching process outside the city on an empty country road. During the gear teach it is not allowed to break, change the gear or activate the clutch. If you must break or activate the clutch anyhow, the gear teach process has to be started again. You perform the gear teach on your own risk! Watch the traffic at any time!

If you chose in menu 5 option (R) and leave the setup with a long push button operation, the gear teach process will start. The display shows a blinking "1".

Engage the first gear and start driving. The blinking "1" change after 3 seconds to a static "1". Now the teach process for the first gear is performed for 4 seconds.

During the run keep the engine speed in the first third of the rpm range on a stable level. After 4 seconds a blinking "2" appears. Now engage the second gear. If the blinking „2“ change to a static „2“ the teach process starts for the second gear.

Keep the engine speed during the run again in the first third of the rpm range in a stable level. Repeat the process to the 6. gear. Important is to engage the gear and release the clutch during the blinking number. During the gear teach (display shows a static number) it is not allowed to break or activate the clutch. If the vehicle has less than 6 gears finish the gear teach process after teaching the last gear by pressing the push button until the start sequence appears.

## **10 Safety instructions**

Do not distract yourself by watching the instrument in public traffic.

The user of the instrument is responsible for the correct setting of all relevant parameters. The user is also responsible for mounting the instrument, the sensors, and all other accessory parts to the vehicle correctly and securely.

# 11 Trouble shooting

## 11.1 After installation

- Make sure the supply voltage is minimum 7V. Check the vehicles battery.
- Do not use a battery charger to test the instrument.
- Check all cables for correct installation and contact.
- Check all cables for correct polarities and short-circuits.
- **Is the SureShift recognising all sensor signals correctly? So you can check it:**
  - Disconnect all wires of the SureShift from vehicle wiring loom.
  - Connect only +12V to the red cable and earth to the black cable.
  - Now the display must be flash two times, if not check the power source and cables for polarity
  - Connect the green cable to the neutral switch and select the neutral gear – if the display shows a "N", this input is working correctly. Disconnect the green cable after this test.
  - Connect the white cable to the speed sensor signal and rotate the wheel which is triggering the sensor - if you can see now a horizontal bar, this input is working correctly.
  - Connect the yellow cable to a ignition coil. Set the Threshold A to 5000 rpm and activate the engine speed ring. Start the engine - if you can see now a ring which is increasing by engine rpm, this input is working correctly.
  - If the test was not successful - do the test explained below.
- **Defective Instrument? So you can check the SureShift inputs:**
  - Disconnect all wires of the SureShift from vehicle wiring loom.
  - Connect only +12V to the red cable and earth to the black cable.
  - Now the display must be flash two times, if not check the power source and cables for polarity
  - Connect the green cable to earth – if the display shows a "N", this input is working correctly. Disconnect the green cable from earth after this test.
  - Inch the white cable to earth - if you can see now a horizontal bar, this input is working correctly.
  - Set the Threshold A to 5000 rpm and activate the engine speed ring. Inch the yellow cable to earth - if you can see now one or more dots on the display, this input is working correctly.
  - If this test was successful, the instrument is working correctly - check your connections to the vehicle. If the test was not successful you have to return the instrument for change.

## 11.2 Return and complains

If you like to return a defective instrument for repair or change please observes following issues:

- Make sure again there is no connection failure. In doubt use a different voltage source to recheck.
- print and fill the repair return form (refer link below) and attach it  
[http://motogadget.com/media/downloads/support/form\\_return\\_repair.pdf](http://motogadget.com/media/downloads/support/form_return_repair.pdf)
- Not prepaid shipments will be rejected.
- The Shipment to motogadget is carried out by your own risk - you are responsible for a sufficient insurance.
- Make sure the package is adequate.
- If you are located outside the EU, you have to declare "repair item" and value 1 Euro in shipment custom declaration.
- Service provided for all not instrument related malfunctions (i.e. defective connection joints, wrong parameter settings and other vehicle related problems) will be charged with 20 EUR.
- Software updates for extending functionality will be charged with 25 EUR.

## 12 Appendix

### 12.1 Connection scheme

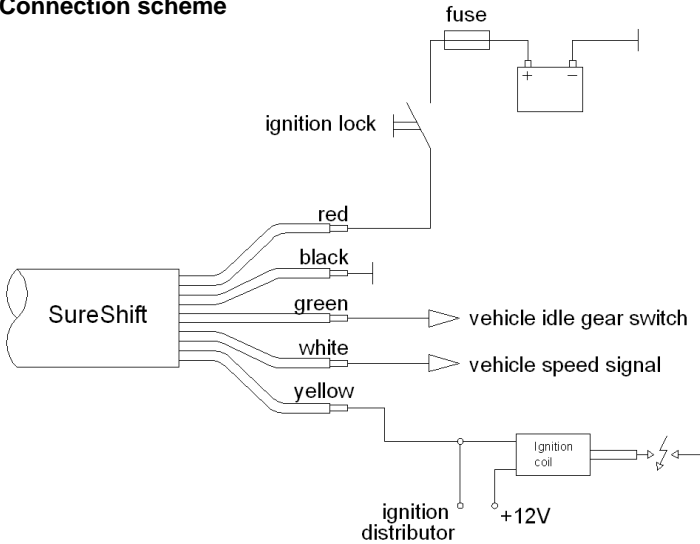

### 12.2 Connection of the temporary push button

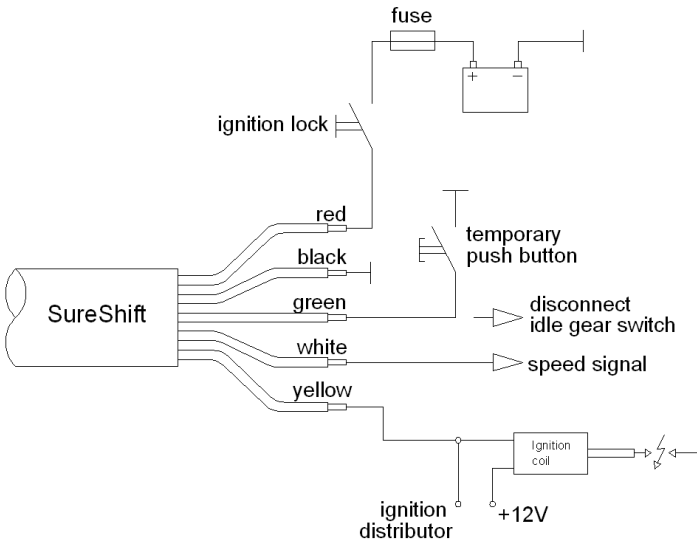

**The *motogadget* team wishes you pleasant and safe riding, and lots of fun with your new SureShift.**

## 12.3 Setup overview

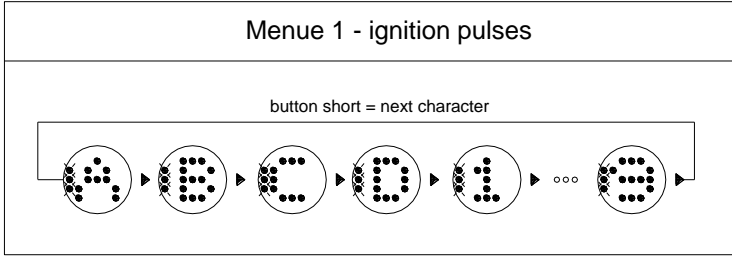

button long = next menu

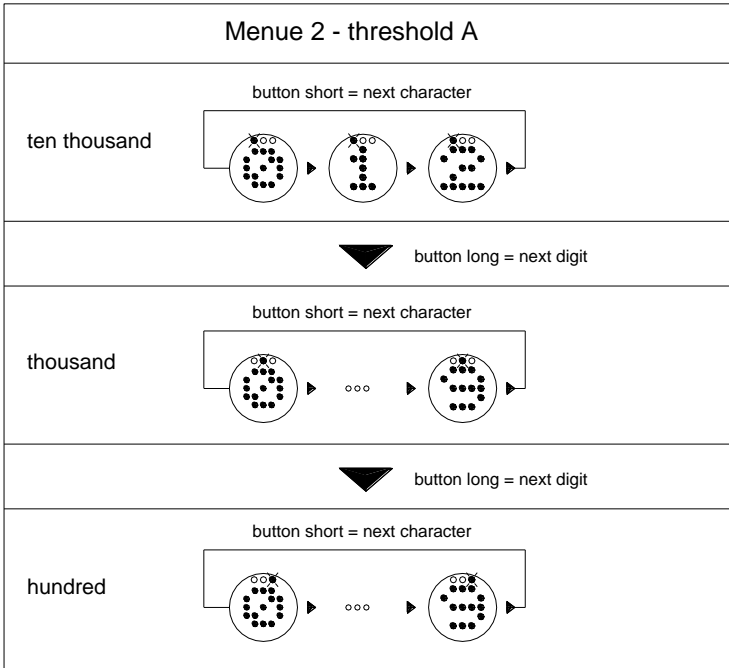

button long = next menu

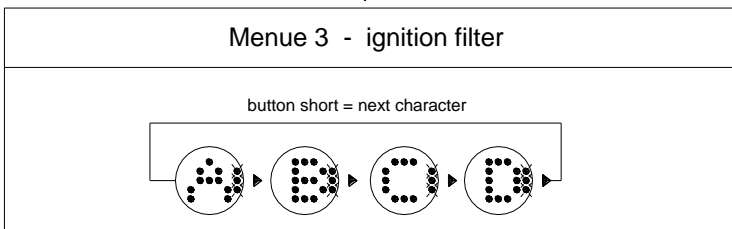

button long = next menu

## Menu 4 - threshold B

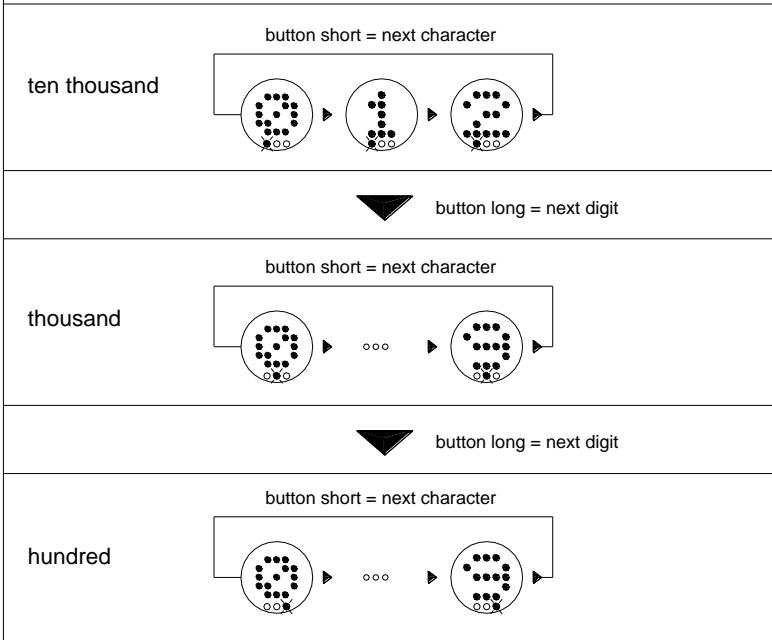

button long = next menu

## Menu 5 - revolution ring on/off + start gear teach

